



CATALOGUE

Equip Your Kitchen for Success

Contents

Buffet Ware Page 1-4

1. Cereal & Beverage Dispensers
2. Premium & Induction Chafers
3. Roll Top Chafers - Elite & Saturn Range
4. Chafer Fuel

Food Service Display Page 5-8

1. Heavy Duty Gastro norm Inserts & Lids
2. GN Series Gastro norm Inserts & Lids
3. Food Display Systems
4. Cake Display Sets

Barware Page 9-11

1. Punch Bowls , Ice Buckets & Wine Stands
2. Barware Accessories : Tot Drainers , Ice tongs , Scoops, Ashtrays , Wine Openers , Bar Blades .
3. Barware Accessories : Mixologist Tools
4. Trays

Beverage Service Page 11-13

1. Trays
2. Tea ware - Tea Pots & Coffee Percolator
3. Service Trollies
4. Tea Ware : Milk Jugs , Frothing Jugs , Sugar Basins

Table Service Page 14-15

1. Tableware : Dome ,Plate Cover s, Sauce Cup's , Butter Dishes etc.
2. Cutlery

Hotel Cookware Page 16 - 20

1. Industrial Casseroles & Stock Pots
2. Sauce Pans
3. Mini Casseroles
4. Fry Pans

Contents

Cook & Bakeware Page 21 - 22

1. Double & Single Roasters
2. Economy Dishes
3. Bowls & Basins : Round , Tapered , Mini Mixers
4. Colanders

Food Preservation Page 23 - 31

1. Araven Storage Containers
2. Araven Black GN Food Pans & Airtight Lids
3. Araven Ingredient Bins
4. Araven Sauce Dispensers
5. Araven Drain Trays

Kitchen Utensils Page 32 - 36

1. Spoons , French Whisk & Ladles
2. Utility Tongs
3. Hamburger Turners
4. Fish Gadgets from ARCOS
5. Portion & Ice Cream Scoops
6. Baker Tools : Pallet Knives , Cake Scarpers
7. Baker Tools : Pastry knives
8. Baker Tools : Measuring Cups & Spoons
9. Baker Tools : Measuring Jugs - Polyprop & Stainless Steel

Kitchen Essentials Page 37- 39

1. Pizza Tools , Mixing Paddles , Lunar Blades
2. Egg Rings & Dredgers
3. Chopping Boards & Racks
4. Cutlery Boxes , Tote Boxes , Magnetic Knife Racks, Bill Holders & Spikes

Contents

Kitchen Knives Page 40 - 54

1. Arcos Riviera Range (Forged)
2. Arcos Universal Range
3. Arcos Block & Knife Sets
4. Arcos Steak Knife Range
5. Arcos 2900 Range
6. Arcos Scissors
7. Arcos Fish Gadgets
8. Arcos Knife Bags
9. Chainmail Gloves
10. Butcher Hooks
11. Arcos Nova Series : Shaping & Paring Knives
12. Arcos Nova Series : Serrated Paring & Table Knives
13. Arcos Nova Series : Cheese & B Line Table Knives

Canteen Service Page 55 - 56

1. Cafeteria Trays
2. Feeding Plates & Mugs
3. Buckets & Lids
4. Prep Bowls
5. Kwik Boil Instant Boiling Water Dispenser

Buyers Information Guide Page 57

Index Page 58 - 59

CEREAL & JUICE DISPENSERS

Our Sunnex range of cereal & juice dispensers is elegant ,durable & cost effective.



BUFFET WARE

Beverage Dispensers

- Ideal for Buffet & self -service
- Transparent Polycarbonate container , stainless steel base, removable drip tray
- Tomlinson faucet can effectively help to prevent leaking. Hollow ice tube assist with keeping juice cool.
- Built in design, attractive and saves space. It is easy to clean and assemble.



5.x23688 JUICE DISPENSER

- 8LT x1 ,
- Size : 360x260x550mm



5.x23888 DOUBLE JUICE DISPENSER / BAY SHAPED

- 10LT (5lt x2) , Multi serving options
- **Size** : 430x385x520mm



5.u14-1000 MINI JUICE DISPENSER

- 5LT x1 ,
- **Size** : 280x220x510mm

Cereal Dispensers

- Ideal for Buffet & self - service
- Transparent Polycarbonate container , stainless steel base
- Suitable for dry foods such as cereal, oatmeal, granola, nuts and more.
- Easy-Turn dispensing knob; portion-control system; won't crush cereal.



5.x23577x3 TRIPLE CEREAL DISPENSER

- Revolving dispenser - space saver
- 4LT x3 - assist with multi serving options
- Includes central handle for easy movement
- **Size** : 315x295x595mm



5.x23677 SINGLE CEREAL DISPENSER

- 7LT x1
- Sturdy stainless steel pole base
- **Size** : 240x330x640 mm



5.u13-1300 TRIPLE CEREAL DISPENSER

- 4LT x3
- assist with multi serving options
- **Size** : 540x240x600 mm



5.u13-1200 2 PART CEREAL DISPENSER

- 4LT x2
- **Size** : 365x240x600mm

Stainless Steel PREMIUM & Induction Chafers

- Dual Purpose Design, can be used with fuel or an induction heating element. Encapsulated bottom bases (Aluminum core encased in Stainless Steel) for even heat distribution, enhances heat performance & heat retention.
- Attractive Build, made of durable, stainless steel with an attractive mirror-polished finish. Four sturdy legs on a secure stand to frame the chafers, ensure stability on your tabletops, while fuel holders offer a safe place to store your chafers fuel.
- Elegant dome cover features a clear glass window that allows guests to see what's inside without lifting the lid. This helps prevent heat loss, food contamination and avoids constant opening and closing of the cover regularly to see what's inside.
- Lids can be detached from bases for easy placement of food pans & easy cleaning.
- Hydraulic Hinge : Lids open to maximum of 90°. Initiate close by pressing down gently, lids fall, closes automatically & silently.
- Each chafers includes adjustable level support, for perfect level placement when required.
- The anti steam droplet system on the lid helps to reduce condensation on the glass which prevents diluted food for a quality taste.
- Solid & secure handle. Spoon Rack provided, to easily hold serving spoons or tongs out of the way, the spoon rack latches onto the chafers side for just this purpose!



7.s60593 INDUCTION RECTANGULAR CHAFER 8.5LT includes;

- 1/1 food pan 65mm
- 1x spoon rest
- Size : 580x440x210mm

7.s62593 RECTANGULAR CHAFER 8.5LT includes;

- Stand, 1/1 food pan 65mm
- 1x spoon rest, 2x fuel holders
- Size : 580x440x330mm



7.s50293 INDUCTION ROUND CHAFER 5LT includes;

- Round food pan 65mm
- 1x spoon rest
- Size : 440x480x210mm

7.s52293 ROUND CHAFER 5LT includes ;

- Stand, Round food pan 65mm
- 1x spoon rest, 1x fuel holder
- Size : 400x440x330mm



7.s60293 INDUCTION ROUND CHAFER 4.8LT includes;

- 2/3 food pan 65mm
- 1x spoon rest
- Size : 400x400x210mm

7.s62293 SQUARE CHAFER 4.8LT includes ;

- Stand, 2/3 food pan 65mm
- 1x spoon rest, 1x fuel holder
- Size : 440x480x330mm

Stainless Steel ROLL TOP Chafers

Elite Roll Top Chafer

- High polish chafer with TITANIUM PLATED LEGS for added elegance
- Dripless circulation design , prevents water overflow, allows water from the lid to drain right back into the water pan. This keeps your surfaces dry to minimize clean up, thus enhancing the overall presentation value.
- Durable , Stainless steel material
- Hydraulic hinge for smooth opening & closing of lids .
- Lid Opening : 180°, detachable for easy cleaning & storage.



7.at51161 ROUND ROLL TOP CHAFER 5LT includes ;

- Round food pan 65mm
- 1x fuel holder
- Size : 510x540x480mm



7.at61161 RECTANGULAR ROLL TOP CHAFER 8.5LT includes ;

- 1/1 food pan 65mm
- 2x fuel holders
- Size : 660x490x460mm

Saturn ROLL TOP Chafers

- Polished chafer with Electrolyzed lid
- Durable , stainless steel material
- Stainless steel Hydraulic hinge for smooth opening & closing of lids .
- Lid Opening : 180°.



7.b51363 ROUND ROLL TOP CHAFER 5LT includes ;

- Round food pan 65mm
- 1x fuel holders
- Size : 500x530x450mm



7.b61363 RECTANGULAR ROLL TOP CHAFER 8.5LT includes ;

- 1/1 food pan 65mm
- 2x fuel holders
- Size : 645x475x435mm

Chafer Fuel

Flaz Chafer gel fuel is essential for reliable chafer heating. This methanol formula provides a high heat with a guaranteed 2 to 3 hour burning output. Flaz is formulated to burn at around 80 degrees Centigrade. This is the ideal temperature to keep food warm in a chafing dish without cooking it, requirements for buffets is that food should be served at temperatures above 60 degrees centigrade hence this is great for any restaurant buffet line or catered event, this series of Flaz Chafer serves as the hottest and most economical fuel on the market.



- Methanol based fuel in a gel consistency
- Odorless
- Smokeless
- Packaged in cases of 24's and 6's, 5 liter bags (papsak),
- 195 grams net. per tin , 2 - 3 hour burn time



Safety Precautions

- Highly flammable liquid and vapor.
- Keep out of reach of children.
- Safety & storage instructions is available on request.



9.fz5682 FLAZ CANNED HEAT 5lt

- Pap sak with non return Tap valve
- Size : 5LT / 260x120x260mm

9.ch FLAZ CANNED HEAT

- Single tins/ cans
- Size : 80mm / 195 grams net



9.6ch FLAZ CANNED HEAT 6 pack

- 6 PACK / (200ml x6)
- Size : 280x110x90mm



9.24ch FLAZ CANNED HEAT 24 pack

- 24 PACK / (200ml x24)
- Size : 350x270x120mm

Related products - Fuel Holders

Fuel Holders , features locked lid mechanism for added safety and a swivel lid for temperature control



61.fhold

- Size : 170x90x63mm

HEAVY DUTY Stainless Steel GASTRONORM INSERT PANS & LIDS

- Stainless Steel
- 430 Material, Gauge .8MM
- Increased Durability
- American Style
- Anti Jam
- Locally Manufactured



430 1/1 - 525x325mm



- 1.430IF20** xh20mm
- 1.430IF55** xh55mm
- 1.430IF65** xh65mm
- 1.430IF100** xh100mm
- 1.430IF150** xh150mm



1.430LF / LID
525x325mm

430 1/2- 325x265mm



- 1.430IH65** xh65mm
- 1.430IH100** xh100mm
- 1.430IH150** xh150mm



1.430LH / LID
325x265mm

430 1/3 - 325x175mm



- 1.430IT65** xh65mm
- 1.430IT100** xh100mm
- 1.IT150 (304)** xh150mm



1.430LT / LID
325x175mm

CONVECTION Oven Rack



1.CRF (201 s/s) 525x325mm



Stainless Steel GASTRONORM INSERT PANS & LIDS - GN SERIES

- Stainless steel 201 , Gauge 0.6 & 0.7mm
- Durable, High heat resistance (from -40°C up to 300°C)
- Anti jam , Stackable
- Rounded edges for easy cleaning
- Dishwasher safe
- European Style / Universal Fit
- Suitable for use in convection ovens, refrigerators, bain-maries and chafing dishes



GN1/1 - 530x325mm

6x



7.GN1-150

530x325xh150 mm



7.GN1-100

530x325xh100 mm



7.GN1-65

530x325xh65 mm



7.PGN1-65/PERFORATED

530x325xh65 mm



7.GN1-20

530x325xh20 mm



7.GL1/ LID

530x325 mm

GN2/3 - 351x325mm

6x



7.GN2/3-150

351x325xh150 mm



7.GN2/3-65

351x325xh65 mm



7.GL2/3 / LID

351x325 mm

GN1/2 - 325x265mm

6x



7.GN2-150

325x265xh150 mm



7.GN2-100

325x265xh100 mm



7.GN2-65

325x265xh65 mm



7.PGN2-65 / PEFORATED

325x265xh65 mm



7.GL2 / LID

325x265 mm

Stainless Steel GN GASTRONORM INSERT PANS & LIDS

FOOD DISPLAY

GN1/3 - 325x175mm

6x 



7.GN3-150
325X176Xh150 mm



7.GN3-100
325X176Xh100 mm



7.GN3-65
325X176Xh65 mm



7.GL3 / LID
325X176 mm

GN1/4 - 265x162mm

6x 



7.GN4-150
265x162xh150 mm



7.GN4-100
265x162xh100 mm



7.GN4-65
265x162xh 65 mm



7.GL4 / LID
265x162 mm

GN1/6 - 176x162mm

6x 



7.GN6-150
176x162xh150 mm



7.GN6-100
176x162xh100 mm



7.GN6-65
176x162xh65 mm



7.GL6 / LID
176x162 mm

GN1/9 - 175x108mm

6x 



7.GN9-100
176x108xh100 mm



7.GL9 / LID
176x108 mm

ACCESSORIES

Food pan Kit for Chafing Dish



7.KIT1GN
525x325xh65 mm
(1x2-65, 2x4-65mm, 1x adapter bar)

Round Food Pan



7.RFP36
360x360x65 mm

FOOD DISPLAY SYSTEM

Full Size Display Sets

- To meet the increasing demand for food displays in the catering industry, we have a series of food display tools which not only present food nicely on the table but are also multi functional to suit your needs.
- All the rectangular items are based on the standard gastronorm specification. They can therefore be mixed & matched to each other.



5.x88189I COOLING DISPLAY SET

- Break-resistant Polycarbonate Roll Top Cover for food viewing
- Reusable Ice Packs Included in each Cooling Display Set.
- Hygienic & Convenient to Use.
- Keep Food Cool & Fresh.

The set includes ;

- 1 x Polycarbonate Black Insert,
- 1 x Full 20mm insert
- 1 x Polycarbonate Roll Top
- 3 x Ice Blocks/ Packs.
- Size : 525x325mm



5.88189I POLYCARBONATE COVER ROLLTOP

- Size : 536x362x176mm

5.52116 PC COVER FULL CENTRE HINGE

- Size : 525x325x70mm

5.c04013 POLYRATTAN BASKET

- Clean & Hygienic
- Made of high quality polypropylene
- Food contact safe , Dishwasher safe
- Size : 525x325x80mm
- Ideal for food presentation and serving for bread, fruit



71.47826 BLACK ABS FULL INSERT 65MM

- Size : 530x325x65mm

Cake Display Sets



4.shcc CAKE COVER

- Size : 300x150mm

4.cstd CAKE STAND

- Size : 325x180mm

5.x52049 CAKE TRAY & COVER SET

- Size : 300x120mm

5.52049a CAKE COVER

- Size : 300x120mm

BARWARE

- Material : Stainless Steel ensuring durability
- High polished mirror finish to add shine and an elegant flair to any display.



SUNNEX

5.12586w PUNCH BOWL

- Stainless steel
- Size : 360mm / 13.5lt



4.cc CHAMPAGNE BUCKET

- Stainless steel
- Size : 225(TD)x180(BD)x255(H)mm / 8lt



4.ib5 ICE BUCKET

- Stainless steel
- Size : 220(TD)x140(BD)x205(H)mm / 4lt

Wine Stands



61.wst100 PRESTIGE STAND FOR WINE BUCKET

- Stainless steel
- Size : 240x640mm



4.fsts FOLDABLE STAND FOR CHAMPAGNE BUCKET

- Stainless steel therefore more durable not chrome
- More anti corrosive
- Foldable for easy storage & transit
- Compatible with the 8LT Champagne Cooler & 4LT Ice Buckets
- Size : 225x720mm



Ice Tongs



4.it ICE TONGS

- Stainless steel
- 180mm

Tot Drainer



1.td TOT DRAINER

- Stainless steel
- 235x180x35mm

BARWARE

Ice Scoops - Polycarbonate & Stainless Steel

- Made of break-resistant polycarbonate, it provides ultimate chip, scratch, and break resistance to withstand the busy environment. Its lightweight plastic construction makes it lighter than metal scoops, incredibly easy to use.



5.84106sc ICE SCOOP

- Polycarbonate
- Size : 170ml



5.84112sc ICE SCOOP

- Polycarbonate
- Size : 350ml



5.84124sc ICE SCOOP

- Polycarbonate
- Size : 700ml



5.84164sc ICE SCOOP

- Polycarbonate
- Size : 1800ml



4.s1 ICE SCOOP

- Stainless steel 201
- Size : 240x80mm

Wine Openers



11.wf11 WAITERS FRIEND WINE OPENER

- Stainless steel & Plastic
- 110 X 30mm

Ashtrays



1.ar2 ASHTRAY ROUND 160mm

1.ar ASHTRAY ROUND 110mm

- Stainless steel



Bar Blades



4.bbs BAR BLADE BOTTLE OPENER

- Stainless steel
- 180 X 40mm

MIXOLOGIST TOOLS - KNIVES

ARCOS



8.188300 ARCOS SHAPING KNIFE 60mm

- Ideal for cocktails , used for Shaping & carving designs
- Inward curve conforms to round objects
- Sharp tip spear like to design
- Effortless peeling & pitting of fruit
- Ergonomic Design , universal fit



KNIVES Paring, refer to page 52-54 for the full range whilst Peelers can be found on Page 34.



BARWARE & BEVERAGE SERVICE

TRAYS - Non slip & Stainless steel

FIBREGLASS TRAYS



IDEAL FOR BAR SERVICE

ROUND TRAYS

- 51.fb1400 355 mm
- 51.fb1600 405 mm



RECTANGULAR TRAYS

- 51.fb1418 360x460mm
- 51.fb1520 380x510mm



POLYPROPOLYNE TRAYS

IDEAL FOR BAR SERVICE

NON SLIP ROUND TRAY

5.nst35b - 355mm



- Rubber inlay surface, resist slip.
- Note the easy-dry feature under the tray.
- The studs separate the trays when they are stacked and allow air to circulate.

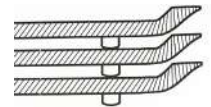

IDEAL FOR FAST FOOD & CANTEENS

RECTANGULAR anti slip Trays



- 51.pt35bl 270x350mm BLACK
- 51.pt41bl 310x415mm BLACK
- 51.pt45bl 350x450mm BLACK



- Textured surface helps reduce slipping and is scratch resistant.
- Easy to clean polypropylene.

Stainless Steel Trays



- 1.ut2
- 430 s/s RECTANGULAR TRAY
- Size : 350x450mm



- 4.rtm35
- 201 s/s ROUND TRAY
- Size : 350mm



- 6.et1 ECONO TRAY 350x450mm
- 6.et2 ECONO TRAY 350x500mm
- 6.et3 ECONO TRAY 400x600mm
- 410 s/s 0.6mm

BEVERAGE SERVICE

Tea Pots & Service Trolleys

The Steel King EVERYDAY BEVERAGE RANGE features modern and practical beverage tea pots & milk jugs, these are perfect for serving hot beverages with durable stainless steel construction in style. The line features bright mirror polished finish tea ware which makes a eye-catching tabletop presentation and is perfect & ready to use at restaurants and hotels.

- 202 stainless steel
- Easy & Non– Drip Pouring spout
- Strong hinged & well fitted lids
- Double handles to ensure safe handling & cool touch
- Strainer built into spout
- Note: Capacity sizes are approximate



- 61.tp50 / Size : 0.40lt
- 61.tp100 / Size : 0.80lt
- 61.tp150 / Size : 1.30lt
- 61.tp200 / Size : 1.75lt
- 61.tp300 / Size : 2.70lt



SPOUTED Tea Pots

61.tp40

- Size : 0.4lt
- 202 s/s .8mm gauge
- Easy non drip short pouring spout
- Secure welding, not easy to detach, more durable and sturdy.
- Elegant rounded body shaped , mirror polishing, beautiful and practical.
- The handle is made of high quality stainless steel, thick and refined, comfortable to hold, easy to use.



Coffee Percolator

Perfect for brewing coffee for groups, this easy-to-use stainless steel coffee percolator quickly makes coffee on both stove top and campfire. With easy and non-drip pouring spout, it comes with a clear knob for easy view. Also, it features sturdy stainless steel for long-lasting durability.

5.cpc

- Size : 9 cup
- Heavy Duty Stainless Steel , Permwod Handle
- Polycarbonate Knob for Easy View and Precision Cooking
- Strong Hinged and Well Fitted Lid
- Includes an Inner s/s Basket with Cover resistant to staining



Service Trolleys

- Square tube trolley bars : s/s for added durability
- Stainless steel tier 18/0, 0.7mm with sound dampers
- Silent swivel castors 100mm(diameter) with 2 Brakes
- Size : 950x500x950mm
- Maximum carrying capacity : 25 kgs per tier
- Supplied with assembly manual



9.t20030 3 TIER TEA TROLLEY

9.t20020 2 TIER TEA TROLLEY

BEVERAGE SERVICE

Milk Jugs , Frothing Jugs & Sugar Basins

The Steel King EVERYDAY BEVERAGE RANGE features modern and practical beverage tea pots & milk jugs, these are perfect for serving hot beverages with durable stainless steel construction in style. The line features bright mirror polished finish tea ware which makes a eye-catching tabletop presentation and is perfect & ready to use at restaurants and hotels.

- 202 stainless steel
- Mirror finished
- Easy non drip pouring spout
- Seamless welding
- Cool touch handle
- Note: Capacity sizes are approximate



- 61.mj085 / Size : 0.08lt
- 61.mj15 / Size : 0.13lt
- 61.mj30 / Size : 0.27lt
- 61.mj60 / Size : 0.55lt
- 61.mj100 / Size : 0.85lt
- 61.mj200 / Size : 1.70lt
- 61.mj300 / Size : 2.6lt



Bellied Milk Jugs

- NON drip Design
- 201 s/s
- Secure welding, durable and sturdy.
- Elegant rounded body shaped, mirror polishing

- 4.bmj0850 / Size : 0.85lt
- 4.bmj15 / Size : 0.15lt
- 4.bmj25 / Size : 0.25t



Frothing Jugs

- Essential tool for baristas and coffee enthusiasts
- Made from high-quality, durable materials
- Rounded pouring spout for precise pouring & latte art
- Comfortable grip handle for easy one-handed pouring
- High Mirror outer Polish
- Secure handle welding, durable and sturdy.
- Capacity of 350 to 1.600 ml as per needs



- 61.fj40 / Size : 0.35lt
- 61.fj60 / Size : 0.60lt
- 61.fj90 / Size : 1.00lt
- 61.fj160 / Size : 1.60lt



Sugar Basin



61.sb30

- Size : 285ml
- Hinged Lid
- Secure welding, not easy to detach, more durable and sturdy.
- Elegant rounded body shaped, mirror polishing.

TABLE SERVICE

Table service refers to the varied ways in which food is presented and served at the table and the objects utilized at the table such as plate covers, sauce bowls and cutlery, a variety of stainless steel in the form of silverware. The style chosen can directly influence the ambience and tone of the event therefore it is key to get it right. Butter Dishes, Plate Covers & Vegetable Dishes are all, **PROUDLY MANUFACTURED IN SOUTH AFRICA**



Dome Dish Cover



5.dm DOME PLATE COVER

- Stainless Steel
- Titanium Plated Dome Knob
- Size : 260mm

Plate Covers



1.pc2 PLATE COVER 260mm
1.pc2s PLATE COVER 230mm

- Heavy duty Stainless Steel
- Plate cover with handles

Vegetable Dishes & Lids



1.vd2 FIXED 2 DIVISION VEGETABLE DISH
1.vd3 FIXED 3 DIVISION VEGETABLE DISH
1.vnd NO DIVISION VEGETABLE DISH

- Heavy duty Stainless steel
- Size : 250mm

Cruet Sets, Salt & Pepper



61.cs3 / JUMBO SALT & PEPPER SET

- Size : ϕ 68x60mm

61.cs2 / MINI SALT & PEPPER SET

- Size : ϕ 42x53mm

Gravy Boats



61.gb10 / Size : 284ml
61.gb05 / Size : 142ml

Salad & Serving Spoons



Refer to Page 33 for the full range.

Sundae Cups

- Stainless steel footed ice cream bowl



4.sun / Size : ϕ 100x48mm



Sauce Cups / Ramekins

- Stackable for easy storage
- Portion control, reduces wastage



4.scup0 / Size : 1.5 OZ

4.scup1 / Size : 2.5 OZ

4.scup3 / Size : 3.0 OZ

4.scup5 / Size : 5.0 OZ



Egg Cups



4.ec EGG CUPS

- Size : ϕ 48x40mm

Finger Bowl



6.16012 FINGER BOWL

- Size : ϕ 120x70mm (0.5Lt)

Butter Dish



1.bdr RECTANGULAR BUTTER DISH

- Size : 500 gms / 200x85x115mm

Toast Racks



4.trck 6 slice

- Size : 170x85x60mm

TABLE WARE

17/0 Cutlery

Inexpensive cutlery is usually manufactured from type 17/0 stainless steel. (17% chrome and no nickel content.) CARE: Staining and pitting is a rare phenomenon but does occur due to bad handling, especially in the inexpensive ranges with no nickel content. Knife blades are made from harder stainless steel in order to achieve a lasting edge but this harder steel has a lower corrosion resistance.

Prolonged contact with water is probably responsible for most staining and pitting trouble. The following guidelines should be noted to avoid any potential problems.

- Wash cutlery immediately after use. Never leave wet overnight and do not use a rinse and hold cycle.
- Wipe dry as soon as a dishwasher has finished its cycle.
- Load the cutlery correctly and use the correct type and quality of detergent.
- Salt is particularly corrosive. After adding salt to your dishwasher make sure that the machine is put through the program recommended by the supplier before washing your cutlery.
- Tap water contains trace elements which leaves a thin film if allowed to dry without wiping.
- Remove from the dishwasher immediately after the cycle is complete, and dry by hand.

ELOFF Economy Range



3.etk	TABLE KNIFE
3.etf	TABLE FORK
3.etbl	TABLE SPOON
3.ets	TEA SPOON
3.edk	DESSERT KNIFE
3.edf	DESSERT FORK
3.eds	DESSERT SPOON
3.erSS	SOUP SPOON
3.esoda	SODA SPOON

18/10 24pc Berlin Cutlery Set **ARCOS**

A modern design featuring Oval lines on a neo-classical inspired handle manufactured from high quality s/steel, the perfect balance of strength and thickness. Arcos Berlin Knives feature micro-serrated edges providing a fine cut and dual service of both a STEAK & Table knife, the special, Martensitic stainless steel guarantees high cutting power and long lasting edge. The rest of the pieces are made of 18/10 Austenitic steel, which ensures corrosion resistant utensil with high polishing. The neo-classical handle design is elegant and bright and made from extra strong material which gives it weight and balance and also keeps it from bending. This series provides a stylish appearance on any table setting and is dishwasher safe. Arcos offers a 10-year warranty based on manufacturing default, under correct & proper use.

The set consist of ;

- 6 x Berlin Tea/ Coffee Spoons
- 6 x Berlin Dessert Spoons
- 6 x Berlin Table Forks
- 6.x Berlin Table/ Steak Knives

8.5624 BERLIN CUTLERY SET 24PC



Hotel Cookware



With quality that outperforms, Steel King Stainless Steel Cookware is built to last, offering you the essentials of cookware! With the utmost versatility, cookware is induction ready with the entire line priced right, making brand and quality affordable. The line is manufactured and designed for the professional industry and is ideal for preparing large quantities.

- Stainless steel with aluminum-clad bottom, so it's tough enough to withstand the rigors of every day use and will serve as the workhorse of your commercial kitchen. Superior in performance at an affordable price .
- Polished satin finish with mirror finish
- Reinforced rims on industrial sizes
- The range features strong sturdy handles position at the top , these loop handles make it easy to lift and transport this pot around the kitchen. Plus, its handles are riveted, to provide a secure connection to the body of the brazier . Extremely durable, hygienic and easy to clean.
- The thick aluminum core allows optimum heating distribution & even heat distribution to the bottom and sides of the pan to eliminate hot spots.
- Suitable for all stove types i.e. gas, hob, induction and electrical.
- The range includes large Casseroles, Stock Pots, standard Sauce Pans & Fry pans



Hotel Cookware

HOTEL CASSEROLES

- Its shorter and wider design allows for more surface area and maximum heat conduction
- Ideal for slow cooking stews , sauces, soups, casseroles and roast whilst reducing content
- Two loop handles are for easy pouring & movement
- Reinforced rims



- 6.SP5-13020** - 300x200mm Casserole 13lt
- 6.SP5-13222** - 320x200mm Casserole 17lt
- 6.SP5-13624** - 350x240mm Casserole 21.5lt
- 6.SP5-14026** - 400x260mm Casserole 31lt
- 6.SP5-14526** - 450x280mm Casserole 43lt
- 6.SP5-15030** - 500x300mm Casserole 56lt

HOTEL STOCK POTS

- Compounded bases for good slow simmer , riveted handles for surety during movement
- From preparing large stocks and soups to boiling large pasta dishes and shellfish, these stock pots help chefs with nearly every culinary creation.
- Smaller diameter and equal height of pot preserves liquid longer and forces the liquid to bubble up through ingredients to maximize flavor transfer.
- Reinforced rims



- 6.Q5-12525** - 250x250 Stock Pot 11lt
- 6.Q5-12828** - 280x280 Stock Pot 16lt
- 6.Q5-13232** - 320x320 Stock Pot 24lt
- 6.Q5-13535** - 350x350 Stock Pot 32.5lt
- 6.Q5-14040** - 400x400 Stock Pot 48lt
- 6.Q5-15050** - 500x500 Stock Pot 95.5lt

Hotel Cookware

LOW RISE CASSEROLE / SAUCE PANS

- Wide Heating Surface allows the cooking of meats & vegetables in limited amounts of liquid
- Evenly distributes heat quickly, and won't pit, discolor, or transfer flavors. Great for browning meat and vegetables, its shallow height and wide diameter provides the need for only a small amount of liquid during the cooking process.
- Also used as a hot bath in conjunction with tapered sauce pans for melting butters , heating sauces or for blanching vegetables.

NEW
CHEF'S PAN
24, 30 & 32cm



- 6.SPL3-124090** - 240x90mm Sauce Pan/Casserole 4lt
- 6.SPL3-1300105** - 300x105mm Sauce Pan/Casserole 7lt
- 6.SPL3-1320110** - 320x110mm Sauce Pan/Casserole 9lt

SAUCE PANS

- Ideal to Sauté, brown , poach, create a stir fry and build sauces
- Narrow width or limited curved sides allow for thorough and efficient whisking of ingredients
- Hanging hole allows for easy storage
- Welded on handles create a strong bond to minimize bacteria collection and allows for easy transport
- Includes lids/ cover helps retain heat and moisture to maximize flavors and prevent spills



- 6.SH3-116095** - 160x95mm Sauce Pan 2.0lt
- 6.SH3-118110** - 180x110mm Sauce Pan 2.5lt
- 6.SH3-120120** - 200x120mm Sauce Pan 3.0lt

Hotel Cookware

MINI CASSEROLE / SAUCE PANS

- Limited Heating Surface allows the cooking of meats & vegetables in limited amounts of liquid
- Ideal for slow cooking which allows the liquid to add juices to the flavor
- Also used as a hot bath in conjunction with tapered sauce pans for melting butters , heating sauces or for blanching vegetables



- 6.SP3-16-1lt** - 160x95mm Casserole 2.0lt
- 6.SP3-18-2lt** - 180x100mm Casserole 2.5lt
- 6.SP3-20-3lt** - 200x120mm Casserole 3.5lt
- 6.SP3-24-6lt** - 240x135mm Casserole 6lt
- 6.SP3-26-8lt** - 260x150mm Casserole 7.5lt
- 6.SP3-28-10lt** - 280x160mm Casserole 9.0lt
- 6.SP3-30-12lt** - 300x180mm Casserole 12.0lt

FRY PANS

- With a wide mouth and side walls, the curved design of this pan makes whisking and stirring a breeze. This unique design minimizes the risk of foods becoming lodged in corners, making it perfect for concocting gourmet sauces and custards as well as easy to clean!
- Ideal for frying, scrambling, sauntering or searing
- Sloped sides prevent steam from forming in the pan



- 6.F1220** - 200x50mm Fry pan
- 6.F1240** - 240x50mm Fry pan
- 6.F1260** - 260x50mm Fry pan



FRY PAN LIDS



- 6.PL200** - 200mm Fry pan Lid
- 6.PL240** - 240mm Fry pan Lid
- 6.PL260** - 260mm Fry pan Lid

ARCOS[®] SAMOA

NON STICK PAN & GRILL

Classic and elegant design , suitable for professional use

COOKWARE

Forged aluminum Body structure that gives it great strength and durability

Base Full Induction Energy Saving, with fast and uniform heat distribution

Cold effect stainless steel handles The best material for heat protection whilst cooking, has a modern, ergonomic and soft-touch finish

Premium Triple layer reinforced NON stick system Designed with a combination of resins and more durable and resistant materials. Highest quality and optimum durability.

PFOA free Environmentally friendly, free of toxic materials.

Easy interior & exterior cleaning, Designed for easy stacking



Ergonomic riveted **stainless steel cool-soft touch** handle



8.7161 - 20CM FRY PAN

8.7163 - 24CM FRY PAN

8.7164 - 26CM FRY PAN

8.7165 - 28CM FRY PAN

8.7166 - 30CM FRYPAN

8.7174 - 28X28CM GRILL PAN



EXCELLENT RELEASE



EXCELLENT DURABILITY



MADE WITHOUT PFOA



MADE WITHOUT PFOS



REGULATORY COMPLIANT



ENERGY SAVING



TRIPLE LAYER REINFORCED NON-STICK



FORGED ALUMINIUM BODY



GAS COOKTOP



INDUCTION



ELECTRIC COOKTOP



OVEN



DISHWASHER SAFE

COOK & BAKEWARE

Robust and durable, that's what you can expect from our proudly South African manufactured merchandise. Significantly heavier and more anticorrosive than their imported counterparts. The designs are simple and practical and have been constant movers for over five decades, making them the obvious choice for both domestic and industrial customers who require quality and longevity from the products they invest in.

PROUDLY MANUFACTURED



IN SOUTH AFRICA

Double & Mini Roasters



1.dr2 DOUBLE ROASTER LARGE

- Size : 380x285x150mm



1.drm MINI DOUBLE ROASTER

- Size : 345x260x150mm



Single Roasters - SK's Dishes

1.SK1 SK DISH SMALL

- Size : 235x180x 35mm (OD) / 200x160x35mm (ID)

1.SK2 SK DISH MEDIUM

- Size : 295x210x40mm (OD) / 255x190x40mm (ID)

1.SK3 SK DISH LARGE

- Size : 335x255x50mm (OD) / 300x235x50mm (ID)

1.SK4S SK DISH EX LARGE - Shallow

- Size : 410x280x55mm (OD) / 355x255x55mm (ID)



Ex Large SK Dishes

1.SK4 SK DISH XL DEEP

- Size : 410x280x75mm (OD)/ 355x255x75mm (ID)

1.SK5S SK DISH GIANT - Shallow

- Size : 490x365x20mm (OD) / 410x335x20mm (ID)

1.SK5 SK DISH GIANT

- Size : 490x365x65mm (OD) / 450x310x65mm (ID)

1.BT (SK6) BUTCHERS TRAY

- Size : 590 x 395 x 50 mm (OD) / 545x350x50mm (ID)



Grill Rack

11.GRID ROASTER GRID (fits 1.DR2 & 1.SK4)

- Size : 325x235mm

COOK & BAKEWARE

Econo Dishes

Econo Dishes are lighter and not nearly as durable as their locally manufactured counterparts. Further, they are made of a type 410 stainless steel which is only mildly anticorrosive. Whilst these products may meet a price point, they are not guaranteed as they do not perform at the level of the locally manufactured counterparts.



- 6.ED2** Size : 270x 200 x 48mm
- 6.ED3** Size : 360 x 270 x 48mm
- 6.ED4** Size : 400 x 300 x 48mm



BOWLS & BASINS

Tapered Bowls



- 1.MB1** SMALL Size : 265 mm DIA 90mm DEEP (2.5Lt)
- 1.MB2** MEDIUM Size : 285 mm DIA 110mm DEEP (3.5Lt)
- 1.MB3** LARGE Size : 310 mm DIA 130mm DEEP (4.5Lt)
- 1.MB4** GIANT Size : 390 mm DIA 105mm DEEP (6.5Lt)
- 1.MB5** GIANT Size : 450 mm DIA 150mm DEEP (12.0Lt)
- 1.MB6** GIANT Size : 480 mm DIA 170mm DEEP (15.0Lt)

Medical Bowl

- 1.MB3WBC** LARGE Size : 340 mm DIA 130mm DEEP (6.0Lt)

Rounded Bowls



- 4.rb7** Size : ϕ 155x45mm (0.5Lt)
- 4.rb15** Size : ϕ 195x60mm (1.0Lt)
- 4.rb30** Size : ϕ 245x90mm (2.0Lt)
- 4.rb50** Size : ϕ 290x90mm (3.6Lt)
- 4.rb80** Size : ϕ 335x125mm (5.0Lt)
- 4.rb130** Size : ϕ 400x120mm (8.0Lt)



Mini Mixing Bowls



- 6.16012** FINGER BOWL / Mini Mixer
Size : ϕ 120x70mm (0.5Lt)

Colanders



- 4.COL3** Size : 245mm
- 4.COL5** Size : 285mm
- 4.COL8** Size : 310mm
- 4.COL13** Size : 380mm





FOOD SAFETY INNOVATION

Araven is an international brand based out of Spain that has been in the market for the last 40 years which designs, manufactures and sells a complete and innovative range of products for professional use in the foodservice sector. Araven collaborates with expert food safety consultants as well as chefs to develop functional products that meet all food hygiene and safety regulations.

Storage Containers

Araven's airtight containers enable foods to be preserved with the maximum hygiene-food safety guarantees, preventing any harmful deterioration and protecting them from cross-contamination. They feature a permanent label amongst other leading technologies which is evident in the success of the range.



BLACK BPA free Gastro norm Food Pans & Air tight Lids

Range of ABS GastroNorm (BPA-FREE) containers with integrated label is ideal for displaying food in cold counters. The versatility of the range is the first of its kind, this enables one container to be used to cover another i.e. It is possible to close one container with another to adapt to the capacity required at any given time. Whilst the air tight lid is a Bi-injection lid with a rubber seal to ensure maximum protection of food, even in large containers. On the operational side these containers allow "mirroring" of handling/cold counter areas and storage/cold cabinet areas to facilitate prepping, batching, serving, adjustment of a container to the type of food contained and to production or consumption batches.



Drain Trays

GastroNorm drain trays are essential elements in any kitchen where food preservation takes place, these are manufactured from high density Polyethylene. Drain trays are ideal to keep food separate from exudates (which contain moisture and nutrients that encourage the growth of bacteria) during thawing.



Sauce Dispensers

Preserve food better and longer with ARAVEN's range of Sauce dispensers, suitable for storage and dispensing of liquid sauces, dressings, syrups only. The dispenser prevents waste by dispensing just the right amount i.e. 30ml per pump. Vertical dispensing: greater ease of use, no spills. The rotatable pump closes the pump circuit so that the contents remain airtight. Not suitable for dispensing sauces with graduals, seeds & chopped herbs.



Ingredient Bins

ARAVEN FOOD SAFETY INNOVATION Ingredient bins is designed for perfect storage, optimum food preservation with maximum hygiene and the strictest control of raw materials. These containers, are the only ones in the world with a permanent label which allows you to detail the content directly on the container thus facilitating food preservation and control. They are ideal for storing food with very low levels of humidity i.e. perfect for the preservation of bulk products in CATERING such as cereals, dried fruits and nuts, rice or pasta i.e. Foodstuffs that do not require refrigeration. They are designed for storage in dry, well-ventilated places away from sources of heat or damp where non-airtight lids are sufficient to prevent humidity from getting in.



PRESERVE FOOD BETTER AND LONGER

New improved airtight seal

Enhanced tightness

- Press down on the lid in the center and gradually close it in the direction in which the air is expelled



It increases the useful life of FOOD

The lid has a channel that allows part of the air inside the container to be expelled, reducing of food and prolonging its useful life by up to **25%***.



New design - double airtight lip on lid.

Easy to Open

- The container has a tab on the lid for easy opening.

FOOD PRESERVATION

POLYPROPYLENE Food Storage Container's



FOOD SAFETY INNOVATION



ColorClip: Color coding to avoid cross-contamination.

Araven containers, thanks to their ColorClip identification, help to prevent cross-contamination, ensuring that the contents of the container are always of the same type: Poultry, red meat, vegetables, fruit, fish or allergen safe.



Integrated label: The permanent label enables catering professionals to identify the contents and record information relating to its origin, thus contributing to compliance with Traceability Regulations Reg. (EC) 852/2004 and Reg. (EC) 178/2002 regarding food.



GastroNorm sizes: Products designed and manufactured according to dimensions and specifications established in the EN 631.1 standard.



Double airtight seal for total protection of the food.
The lid is made of LDPE, a more flexible material, which allows a better fit to the base.



High heat resistance: 203 °F.
Good behaviour at low temperatures -40 °F. Good balance of strength–weight characteristics



Rounded edges: The special design avoids the accumulation of remains of food and facilitates EASY cleaning.



Enables food to be identified.
The balance of strength–weight characteristics, its rigidity and behaviour at different temperatures make this plastic the most popular solution used by catering professionals for food preservation.



Measuring scale



Stackable with a lid and nestable when empty.



Can be washed in dishwasher. Good surface resistance and resistance to chemicals. Scarce water absorption.



Compliance with all European regulations regarding materials and objects intended to come into contact with food.



MATERIAL: POLYPROPYLENE



Polypropylene · Airtight Containers



FOOD PRESERVATION



GN1/1

6x



71.03038/27,5L
530x325xh200 mm



71.03037/20,5L
530x325xh150 mm



71.03036/13,7L
530x325xh100 mm



71.03044/8,3L
530x325xh65 mm

GN2/3

6x



71.00470/ 14L
354x325xh150 mm



71.03469/9L
354x325xh100 mm

GN1/2

6x



71.03035/12,5L
325x265xh200 mm



71.03034/10L
325x265xh150 mm



71.03033/6,5L
325x265xh100 mm



71.03032/4L
325x265xh65 mm

Polypropylene · Food Storage Containers



GN1/3

6x



71.03029/2,5L
325x176xh65 mm



71.03030/4L
325x176xh100 mm



71.03031/6L
325x176xh150 mm

GN1/4

6x



71.03026/1,8L
265x162xh65 mm



71.03027/2,8L
265x162xh100 mm



71.03028/4,3L
265x162xh150 mm

GN1/6

6x



71.03023/1,1L
176x162xh65mm



71.03024/1,7L
176x162xh100 mm



71.03025/2,6L
176x162xh150 mm

GN1/9

6x



71.03020/0,6L
176x108xh65 mm



71.03021/1L
176x108xh100 mm



71.03022/1,5L
176x108xh150 mm

RELATED PRODUCTS

GN DRAIN TRAYS/ GRILLS : Enable liquids to be separated from the food, refer to page 31



HORECA Marker. Permanent, water-based ink. **71.00393**
Resistant to abrasion and cold chamber condensation. Can be washed away.



FOOD PRESERVATION & DISPLAY

Black ABS Gastronorm Food Pans & Airtight Lids



FOOD SAFETY INNOVATION

FOOD PRESERVATION

Araven's new range of bisphenol-free black containers, made in ABS (Acrylonitrile butadiene styrene), ensures high impact resistance, very robust and durable product, this line is designed for handling and displaying food at cold counters as well as for storage using airtight lids. It allows "mirroring" between handling /cold counter areas and storage/cold cabinet areas, to facilitate prepping, batching and serving. This process makes it easy to adapt containers to the type of food contained and to production or consumption batches.



The GastroNorm airtight lids are bi-injection molded with rubber seal to ensure maximum protection of foodstuff even in large containers. For display purposes the black finish GastroNorm is available in sizes (GN 1/6, 1/2, 1/1) these containers are versatile, elegant items for buffet counters, self-service restaurants and system catering establishments.



Permanent Label



Versatility : Container closed with another container



Airtight



Ergonomic



Gastro norm Sizes



Temperature °C



Measuring Scale



GN1/6

6x



71.47797 /1,5L
176x162xh100mm



71.47798 /2,15L
176x162xh65mm



71.09852
176x162x22mm

GN1/2

6x



71.47822 /6L
325x265xh100mm



71.09855
325x265x22mm

GN1/1

6x



71.47826 /8,35L
530x325xh65mm



71.47827 /13L
530x325xh100mm



71.09856
530x325x22mm

Ingredient Bins

Optimize space and improve accessibility

FOOD PRESERVATION



ARAVEN FOOD SAFETY INNOVATION Ingredient bins are designed for perfect storage, optimum food preservation with maximum hygiene and the strictest control of raw materials. These containers, are the only ones in the world with a permanent label which allows you to detail the content directly on the container thus facilitating food preservation and control. They are ideal for storing food with very low levels of humidity i.e. perfect for the preservation of bulk products in CATERING such as cereals, dried fruits and nuts, rice or pasta i.e. Foodstuffs that do not require refrigeration.

They are designed for storage in dry, well-ventilated places away from sources of heat or damp where non-airtight lids are sufficient to prevent humidity from getting in. Ingredient Bins are made of polypropylene and polyethylene.

They increase efficiency in handling and storage processes. They help to optimize space by means of efficient food storage methods, leading to reductions in waste and improved stock rotation. Ingredient bins specially designed to store dry, non-perishable or bulk foodstuffs that do not require refrigeration, in correct conditions of temperature and humidity



Greater Stock control Accessible GN 1/1 containers are designed with the FIFO (first in - first out) with top loading and unloading. Facilitates correct rotation of food. Separate filling and removing in GN 1/1 to facilitate control of contents. HACCP Recommendation



Transparent: the front window, & integrated label and transparency of the piece allow quick identification of the food and its contents. **Permanent traceability label:** Allows the origin of the food, its preparation date, expiration date etc. to be recorded.

Ingredient Bin's

Optimize space and improve accessibility



FOOD SAFETY INNOVATION



FOOD PRESERVATION

4x



71.09146/3.7L
395x200xh200mm

4x



71.09144/22.65L FIFO SYSTEM
565x340xh200mm

3x



71.00918/50L FIFO SYSTEM
565x340xh400



Bulk Ingredient Bins

2x



71.00919/80L
655x435xh560 mm



71.00920/100L
705x465xh580 mm



HDPE



Easy accessibility: You can access the contents of any of the stacked containers without unstacking. The lid is raised in the open position without having to hold it.



Sliding lid designed for greater accessibility, applicable to 80 & 100 L. The front lid, integrated label and transparency of this product enable the food to be identified at a glance



ColorClip: Colour coding to avoid cross-contamination of food. Applicable to 71.09146, 71.09144, 71.00918 only



Tough polyamide wheels for the 80L and 100L sizes to facilitate transport

FOOD PRESERVATION

Sauce Dispensers



Popular for storage and dispensing of sauces, dressings, syrups... Easy to fill - reduce waste levels by pumping out only the amount required. Optimization of space: It takes up very little space and can be kept in the kitchen or made available directly to consumers. Suitable for front of the house self-service areas. Enhances the presentation of sauces in serving and display areas. Useful for carrying the dispensers to their storage place.



Gastro Norm sizes: Products designed and manufactured according to dimensions and specifications established in the EN 631.1 standard.

Integrated label: The permanent label enables catering professionals to identify the contents and record information relating to its origin, thus contributing to compliance with Traceability Regulations.

Vertical dispenser: Greater user convenience, no accidental spills.

Shutoff valve keeps the pumping circuit closed, improving preservation of product in the container, even in cold storage.

Color Clip: Colour coding to avoid cross-contamination.

Double airtight seal for total protection of the food. The lid is made of LDPE, a more flexible material, which allows a better fit to the base.

Measuring scale for perfect control of stocks.

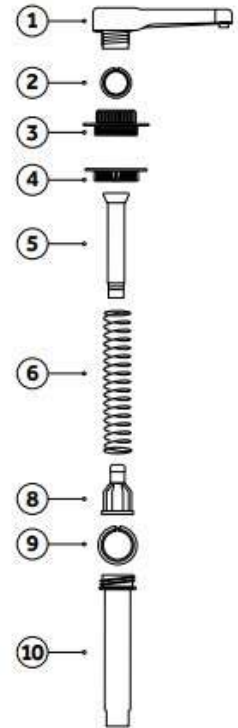

71.02784
PUMP DISPENSER - 30ML



71.01362/1.5L
176x108x190mm



71.01367/2.6L
176x162x190mm

GN DRAIN TRAYS/ GRILLS : Enable liquids to be separated from the food

They are used in the preservation of foods that release juices, reducing the amount of losses due to spoilage. Fresh meat and fish release a liquid called residual liquid. It contains nutrients and water that can encourage the proliferation of bacteria, with a resulting potential health hazard. Correct preservation of this type of food requires the use of drain trays that separate the exudate from the food. The drain trays used for this purpose must be high enough to avoid the exudate flowing over the drain trays and their design must avoid sharp edges, corners and nooks where the exudate can accumulate. The drain tray is placed in the bottom of the container and encourage drainage to the bottom, thus avoiding contact between the liquid and the food and reducing the risk of proliferation of bacteria.



Optimum shape: Designed to correctly evacuate exudates. High enough to separate exudates from food. **Rounded edges:** A special design that avoids accumulation of food remains and makes cleaning easier. **Gastro Norm sizes:** Products designed and manufactured according to dimensions and specifications. **Ergonomic:** An ergonomic edge to facilitate handling of the grill.



71.000256 · GN 1/1
470x265xh20mm

71.00241 · GN 1/2
260x205xh20 mm

71.00242 ·GN 1/3
260x115xh20 mm

71.00254 ·GN 1/6
120x106xh20 mm

Kitchen Utensils



KITCHEN UTENSILS

Basting Spoons , Turners & Pot Forks



4.bsps330

- Perforated
- Size : 330mm



4.bsp330

- Solid
- Size : 330mm



4.bsps

- Perforated
- Size : 390mm



4.bsp

- Solid
- Size : 390mm



4.bta

- Slotted Turner
- Size : 350mm



4.bfk

- Pot Fork
- Size : 350mm

Serving Spoons

2.ssp

- Solid Serving Spoon
- Size : 240mm

4.csp

- Solid Curry Spoon
- Size : 250mm

4.rsp

- Solid Rice Spoon
- Size : 270mm

2.ss

- Salad Server Set
- Size : 240mm

71.41704

- Solid Black PP Serving Spoon
- Size : 333x73mm



French Whisk

- Stainless steel strong sturdy wired whisk ideal for heavy duty product

4.fw30

- Size : 300mm

4.fw35

- Size : 350mm

4.fw40

- Size : 400mm

4.fw45

- Size : 450mm

4.fw50

- Size : 500mm

Ladles

- Single Piece



4.ls1 - 1oz

- 30ml



4.ls2 - 2oz

- 59ml



4.ls4 - 4oz

- 118ml



4.ls6 - 6oz

- 177ml



4.ls8 - 8oz

- 237ml



4.ls12 - 12oz

- 354ml

KITCHEN UTENSILS

Utility Tongs

araven



71.41705

- BLACK Scallop Tong Size : 230mm
- Maximum resistance and durability made of PC.
- Ideal for serving hot and cold food.
- Ergonomic design for easy & perfect grip of food
- Great for serving salads, buffet tables and food stations



4.tong 9

- Utility Tong
- Size : 250mm

4.tong 12

- Utility Tong
- Size : 300mm

4.tong 16

- Utility Tong
- Size : 400mm

Vinyl Colored Utility Tongs

- Made from commercial-grade, durable stainless steel, Size : 300mm
- Scalloped end design improves grip when clamping onto any meats or ingredients
- Vinyl-coated handles offer corrosion resistance, abrasion & heat resistance
- Available in HACCP Colors, tongs are essential in all kitchens, as they are widely used for all types of food.

- 4.vt30B - BLUE
- 4.vt30G - GREEN
- 4.vt30R - RED
- 4.vt30Y - YELLOW
- 4.vt30W - WHITE

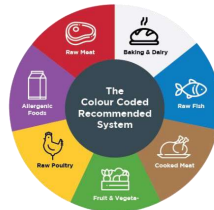

Hamburger Turners

- Flexible stainless steel blade designed for lifting and flipping.
- Comfortable Black polypropylene plastic handle, for easy grip
- This turner series is perfect for flipping burgers or turning steaks, the flexible stainless steel blade slides under food with easy.

5.mphft38k

- Solid
- Size : 375x72mm
- Blade : 200x72mm



5.mphft

- Perforated
- Size : 375x72mm
- Blade : 200x72mm



5.mphhtk

- Solid
- Size : 285x70mm
- Blade : 120x70mm



Peelers & Fish Gadgets from **ARCOS**

8.6070

Potato Peeler

- Blade (L) : 50mm
- Full (L): 120mm



8.6050

Fish Tweezer

- Blade (L) : 110mm
- Full (L): 130mm



8.7905

Fish scaler

- Blade (L) : 110mm
- Full (L): 260mm



KITCHEN UTENSILS

Portion Disher / Ice Cream Scoops



- Multiple use disher scoop. Ideal for portioning cookie dough, cupcake batter, meatballs, mashed potatoes, and more.
- 304 stainless steel bowl, stain-resistant, won't pit, rust or corrode.
- Assist with precise portion control, helps manage food costs & reduce wastage
- Ribbed handle for comfort, Right hand thumb lever
- Allows easy release of contents, Ideal for serving soft foods.
- Color-Coded for Size Identification and Portion Control



51.ics30-blk

- No. 30 Disher
- Size : 30ml



51.ics24-red

- No. 24 Disher
- Size : 40ml



51.ics20-ylw

- No. 20 Disher
- Size : 48ml



51.ics16-blu

- No. 16 Disher
- Size : 59ml



51.ics12-grn

- No. 12 Disher
- Size : 79ml

Ice Cream / Soft Dough Scoops

- 304 Stainless Steel Squeeze Handle Ice Cream Dishers / Cookie Dough Scoop
- Spoon shape: Round, Ambidextrous squeeze i.e. handle is comfortable for use in either hand
- Use with whole hand instead of thumb to reduce fatigue
- Great for serving portions of soft foods like rice, meat, potatoes, and desserts
- Consistent scoops maximize profits and minimize food waste



51.ss-ics50

- No. 50 / Size : 22ml



51.ss-ics24

- No. 24 / Size : 39ml



51.ss-ics12

- No. 12 / Size : 79ml



Ingredient Scoops : Polycarbonate & Stainless Steel



5.84106sc ICE SCOOP

- Polycarbonate
- Size : 170ml



5.84112sc ICE SCOOP

- Polycarbonate
- Size : 350ml



5.84124sc ICE SCOOP

- Polycarbonate
- Size : 700ml



5.84164sc ICE SCOOP

- Polycarbonate
- Size : 1800ml



4.s1 ICE SCOOP

- Stainless steel - 201
- Size : 240x80mm

KITCHEN UTENSILS

For the baker - Icing tools



Palette Knife & Cake Scrapers

The spatula is perfect for spreading icing onto a cake or pushing batter into an even layer in a pan, whilst Cake scrapers provide straight edges & gives a smooth finish to the final product.



- Flexible & durable stainless steel blade for smoothing
- Easy to grip black polypropylene plastic handle

- Stainless steel scraper for decorating cakes
- For spreading icing or buttercream
- Ideal for tall or wide cakes

1.scr1 - Size : 150x75mm
1.scr2 - Size : 235x90mm

5.mphsp08k - Size : 200mm
5.mphsp10k - Size : 250mm



The **Universal 250mm pastry spatula** has a straight shape with a rounded tip, and is perfect for pastry work.

8.286204



Pastry Knife



250mm blade, wide and strong. Used to cut, section, and slice bases for cakes.

8.293225

Measuring Spoon & Cup Sets



4.mss

- Stainless steel 4 pc
- Size : 1.25, 2.5 , 5 & 15ml



4.mcs

- Stainless steel 4 pc
- Size : 60, 80 , 125 , 250ml

Measuring Jugs - Polypropylene

- The Sunnex polypropylene measuring jug offers excellent resistance and long lasting durability.
- Graduated with printed liters and embossed with milliliters markings.
- The wide, tapered spout improves pouring accuracy & feature an open ended handle making the jug quick and easy to grasp.

5.86021 - Size : 0.5Lt
5.86121 - Size : 1.0Lt
5.86221 - Size : 2.0Lt
5.86321 - Size : 3.0Lt
5.86521 - Size : 5.0Lt



Measuring Jugs - Stainless Steel

- 18/8 stainless steel , heavy duty , durable
- Graduated measurements inside
- Easy to grip secure handle for easy movement & handling

61.mej100 - Size : 1.0Lt
61.mej200 - Size : 2.0Lt



KITCHEN ESSENTIALS

Pizza Tools - Shovels & Turners

- Heavy Duty , 430 Stainless Steel
- Twice as thick in comparison to industry norms



11.ps34l

- **Long Handle Shovel**
- Size : Diameter 345X345mm, L: 1800mm

11.ps30s

- **Short Handle Shovel**
- Size : Diameter 345X345mm, L: 780mm



11.pr23l

- **Long handle Turner**
- Size : Diameter : 230mm, L: 1700mm

Mixing Paddle



4.mp30

- Stainless steel
- Size L: 780mm

Pizza Cutter



11.lb320

- 430 stainless steel
- Reinforced design for added pressure & precise cutting
- Size : 320mm

Egg Rings

- Heavy duty
- 430 stainless steel
- Size : 95mm



11.er95



11.es95

Salt Dredgers



- 4.dred Size : 70x90mm / 0.3Lt/ 10 oz
- 4.dred2 Size : 70x145mm/ 0.5Lt/ 16 oz
- 4.dred3 Size : 70x185mm / 0.7Lt/ 22oz

KITCHEN ESSENTIALS

Chopping Boards



Professional color coded chopping boards helps to segregate different food groups & avoid cross contamination, which ensures HACCP compliance .

- Made from LDPE - Polyethylene plastic, ensures the boards resistance to bending , chipping & cracking .
- NON - Absorbent & NON - Porous surface will not absorb liquids or harbor bacteria , stain resistant & easy to clean .
- Available in BLUE, RED, GREEN, BROWN, WHITE, YELLOW, & PURPLE (available in the large size only).



51.l5038blu/brwn/grn/red/wht/ylw/pur

- Size : LARGE 510x380x13mm

Prevent Cross Contamination
Use correct colour coded chopping boards and knives at all times

- RAW MEAT
- RAW FISH
- COOKED MEATS
- SALADS & FRUITS
- VEGETABLES
- DAIRY PRODUCTS
- ALLERGENS



51.s3825blu/brwn/grn/red/wht/ylw

- Size : SMALL 380x250x13mm

Chopping Board Racks



51.cbr : 320x230x160mm

- Solid PP chopping board rack 6 DIV
- Strong, sturdy and stable,
- Collapsible, easy to assemble & easy storage
- Tier design allows effective display for easy referencing
- Well spaced divisions allows boards to dry quickly
- Ideal for use in commercial & domestic kitchens.
- Dishwasher-safe , making cleaning effortless.

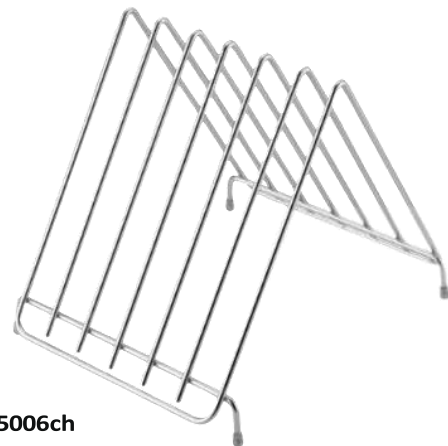

61.15006ch

- Stainless steel 6 division Rack
- Size : 300x270x280(H)mm , Slot width 30mm
- It allows for fast drainage to prevent bacteria breakout.
- Made with quality anti rust stainless steel material.
- Sturdy and hold effectively 6 chopping boards.
- Highly durable product and a good storage for boards

KITCHEN ESSENTIALS

Cutlery Box 4 DIVISION



3.cbox CUTLERY BOX 4 COMPARTMENT - GREY

- Made of durable, commercial grade, polypropylene plastic
- Ideal for storage/dispensing of silverware and condiment packets
- Durable and easy to clean
- Size : 550x310x100mm

Tote Box



5.tb TOTE BOX

- Polypropylene Material
- Durable and easy to clean
- Great bus box for clean up, storage, and more in the kitchen
- Size : 550x410x135mm

Magnetic Knife Racks / Strips



3.mk48 / Size : 485x35mm

3.mk55 / Size : 550x48mm

- Quickly and confidently access the knives you need most.
- Hang your knives on the wall to save valuable drawer space and provide more convenient access. This simple solution helps rid the clutter of a bulky knife block and provides better protection for your cutting tools without any friction. It is compact enough to fit into tight spaces and can be easily mounted on kitchen walls.
- Attach the included screws to install it on the wall.

Bill Holders



6.bh-71036

- Size : 910x25x80mm

Bill Spikes



4.bspk

- stainless steel
- Size : 90x170mm

ARCOS®

Premium Quality Knives Made in Spain - Since 1734

The origins of this Spanish knife manufacturer date back to 1734 when Juan de Arcos first crafted a pair of desk scissors in Albacete, Spain. Three centuries later, Arcos have continued to innovate and have become the leading European knife manufacturer that they are today. Their knives are characterized by the use of NITRUM® stainless steel, exclusive to Arcos, which improves performance and durability by increasing the hardness of the blade, resulting in greater cutting power, increased sharpness and improved edge retention. All products are NSF Approved and far exceeds the performance criteria of ISO 8442.

NITRUM®

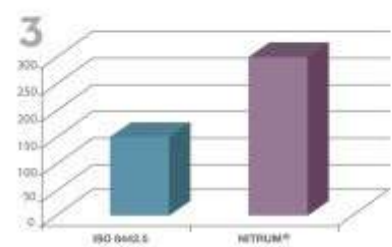
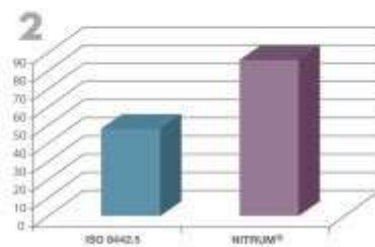
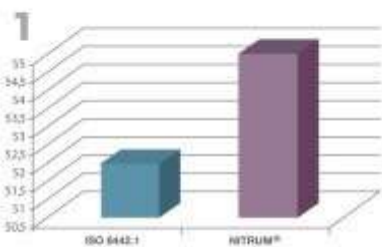

HARDNESS TEST

ISO 8442.1

NITRUM exceeds the ISO8442.1 Standard by more than 3 HRC

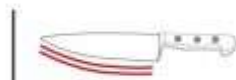

INITIAL CUTTING POWER

ISO 8442.5

NITRUM tested 70% higher than the ISO8442.5 norm



CUTTING EDGE RETENTION (EDGE DURABILITY)

ISO8442.5

NITRUM tested at 200% higher than the ISO 8442.5 norm

How to Correctly Sharpen Your Arcos Knife

- Arcos recommends the regular use of a sharpening steel to keep the cutting edge of your knife razor sharp. Place the blade of the knife on the steel at a 20 degree angle.
- Keep the arm that is holding the steel steady and swipe the blade lightly over the steel keeping the angle at 20 degrees. Give each side of the knife an equal number of swipes (about 20).
- Sharpen the other side of the blade as before, this time using the other side of the honing steel. And remember to always protect your fingers.

Tips For Use and Maintenance

- Wash knives immediately after use with a mild soap. Avoid prolonged contact with leftover food. Do not use bleach, soda or detergents containing chlorine or chlorides ions because they rust the steel and may cause it to lose its shine.
- Avoid rubbing your knives with abrasive products, hard cloths, and metallic or synthetic cleaners. If you use a dishwasher, place your knives in with the blades facing up and in separate containers from the rest of your cutlery to avoid scratching.
- Avoid leaving your knives submerged in water for long periods of time, especially in hard or salty water that can affect metals. Dry immediately with a soft cloth.
- Leaving your knives to dry in the dishwasher is not recommended.



ARCOS®

RIVIERA

BLADE NITRUM® Stainless Steel

Its exclusive nitrogen treated steel composition provides additional hardness, greater cutting power & improved cutting edge technology

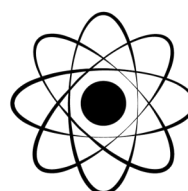

Forged Steel

Subjected to a red hot deformation forging process whose results is a solid one piece knife



HANDLE



BACTIPROOF SILVER®

An anti-bacterial system combination applied to the handle which reduces by 99.9% the presence of bacteria, fungi or mould.



The Arcos innovative spirit has led to a collaboration with AIMPLAS (Plastic Technology Centre) to obtain the most reliable materials, for food grade safety which gives the knife handle high chemical & mechanical resistance and high durability. Every Riviera Knife is fitted with a polyoxymethylene (POM) handle which handles temperature changes far better in comparison to polypropylene, the handle also boasts an outstanding design since its rounded ferrule was inspired by the French style.



Endorsed by the prestigious North American NSF (National Sanitary Foundation) certification on food safety.

Stainless Steel Rivets

Stronger clamping force which increases corrosion resistance.



RIVIERA



8.230200

- Paring Knife
- Blade (L) : 100mm
- Full (L): 202mm



8.231500

- Boning Knife
- Blade (L) : 130mm
- Full (L): 251mm



8.233000

- Slicing/ Fillet Knife
- Blade (L) : 200mm
- Full (L): 319mm



8.231000

- Slicing/ Fillet Knife
- Blade (L) : 250mm
- Full (L): 374mm



8.233300

- Carving Fork
- Blade (L) : 180mm
- Full (L): 320mm



8.233500

- Sushi / Japanese Knife
- Blade (L) : 180mm
- Full (L): 310mm



8.233400

- Cooks Knife
- Blade (L) : 150mm
- Full (L): 272mm



8.233600

- Cooks Knife
- Blade (L) : 200mm
- Full (L): 327mm



8.233700

- Cooks Knife
- Blade (L) : 300mm
- Full (L): 378mm



8.231300

- Bread Knife
- Blade (L) : 200mm
- Full (L): 323mm

ARCOS[®] UNIVERSAL

Made for everyday use without sacrificing design, the ergonomic, slip-resistant, handle provides a firm and comfortable grip.



BLADE

NITRUM[®]

Stainless Steel

Its exclusive nitrogen treated steel composition provides additional hardness, greater cutting power & improved cutting edge technology

HANDLE



An anti-bacterial system combination applied to the handle which reduces by 99.9% the presence of bacteria, fungi or mold.



The Arcos innovative spirit has lead to a collaboration with AIMPLAS (Plastic Technology Centre) to obtain the most reliable materials, for food grade safety which gives the knife handle high chemical & mechanical resistance and high durability.

Stainless Steel Rivets

Stronger clamping force which increases corrosion resistance.



Endorsed by the prestigious North American NSF (National Sanitary Foundation) certification on food safety.



UNIVERSAL



8.280204

- Paring Knife
- Blade (L) : 100mm
- Full (L) : 200mm



8.282604

- Boning Knife
- Blade (L) : 160mm
- Full (L) : 288mm



8.280404

- Chefs Knife
- Blade (L) : 155mm
- Full (L) : 270mm



8.280601

- Chefs Knife
- Blade (L) : 200mm
- Full (L) : 323mm



8.280604

- Chefs Knife
- Blade (L) : 200mm
- Full (L) : 323mm



8.280704

- Chefs Knife
- Blade (L) : 250mm
- Full (L) : 390mm



8.281604

- Cheese Knife
- Blade (L) : 145mm
- Full (L) : 277mm



8.286004

- Sushi Knife
- Blade (L) : 170mm
- Full (L) : 294mm



8.2841

- Carving Fork
- Blade (L) : 160mm
- Full (L) : 268mm



8.281504

- Carving Knife
- Blade (L) : 190mm
- Full (L) : 304mm



8.282104

- Bread Knife
- Blade (L) : 200mm
- Full (L) : 320mm



8.283904

- Pastry Knife
- Blade (L) : 250mm
- Full (L) : 383mm



8.286204

- Spatula Knife
- Blade (L) : 250mm
- Full (L) : 390mm

ARCOS® KNIFE SETS

Block Sets

We introduce the **Riviera Blanc Range**, forged from a single piece of Nitrum® stainless steel, exclusive to Arcos, with a French style ferrule; this series combines personal rounded lines with comfort and ease of handling.



8.234524

- The range features ; Nitrum® forged stainless steel blades provides more hardness, higher sharpness and improves edge retention
- Ergonomic Riviera white handles is designed to fully adapt to the shape of the hand, for safety and comfort
- Handle scales made of polyoxymethylene (POM), with a smooth finish and highly resistant to high and low temperatures and corrosive products (-40°C to 150°C)
- Stainless steel rivets ensure high corrosion resistance
- French style bolster
- The set includes
 - 1x Paring knife blade (L): 100mm, Chef's knife blade (L): 150mm
 - 1x Chef's knife blade (L): 200mm, 1x Bread knife blade (L) 200mm
 - 1x Kitchen shears, (L): 200mm, 1x Block

UNIVERSAL



8.285000

- The set includes
 - 1 x 100mm Pairing Knife
 - 1 x 150mm Chef's Knife
 - 1 x 175mm Chef's Knife
 - 1 x 195mm Kitchen Scissor
 - 1 x Pine wood knife block



Knife Sets



8.8490

- B LINE Series features a fine micro serrated blade.
- Used to cut steak fillets and lightly grilled meat with little effort.
- Water resistant handle
- Blade (L) : 100mm
- Full (L): 215mm



8.8590

- Nova Series includes 85mm domestic paring knives , these are specially designed for Peeling effortlessly...
- Each knife is small, light and manageable with a sharp tip, ideal for fruit and vegetable.
- A perfect knife combining simplicity and efficiency.
- Blade (L) : 85mm
- Full (L): 200mm



ARCOS® STEAK KNIVES



Nordika Series Barbecue Set 8.1670

- The **100% natural ovegkol wood handle** comes from FSC® certified, well-managed forests.
- The knife features an exclusive Arcos nitrogen steel formula, which gives it greater hardness, high quality cutting edge & long-lasting durability.
- The blade features a curved design, is 215mm in length, its **Silk thread** provides a smooth and precise cut with high performance and durability.
- The handles has **three brass rivets** that guarantee an excellent union of the frame and the steel.
- **Rounded handle** softens the **grip and avoids rubbing on the hand, increasing ergonomics** during use.

Every Day Steak Knives

Serrated Blades manufactured using the patented Nitrum®, handles is made of polypropylene, a synthetic material resistant to heat and chemical products. It has a lightweight and ergonomic design, which adapts to the shape of the hand.

8.7397

- Steak & Veg Knife
- Blade (L) : 105mm
- Full (L): 220mm



8.7400

- Wide Blade Steak Knife
- Blade (L) : 115mm
- Full (L): 230mm



8.188800

- Round Tip Steak Knife
- Blade (L) : 110mm
- Full (L): 200mm



Mono Block Series, Steak Knife & Fork

Manufactured from a single piece of steel, this steak knife has an extremely long-lasting serration which ensures high cutting power & durability.

- Light & easy to handle, Ergonomic handle
- Pearl edge, ensures the knife remains in excellent cutting condition for a long time.
- Dishwasher safe, although manual cleaning is recommended

8.7020

- Steak Knife
- Blade (L) : 110mm
- Full (L): 220mm



8.7021

- Steak Fork
- Blade (L) : 95mm
- Full (L): 200mm

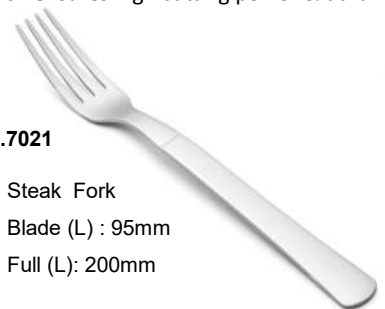

Wooden handle wide blade Steak Knife

This steak knife 120mm with compressed beech **wood** features a wide blade design with a pearled edge and ergonomic handle.

FEATURES ;

- Ergonomic handle made of compressed beech wood, very light and resistant. Riveted for added security.
- Serrated Pearled edge that does not need sharpening.
- Dishwasher safe, although manual cleaning is recommended

8.372700

- Blade (L) : 120mm
- Full (L) : 230mm



ARCOS® 2900 SERIES

Designed for professionals who require prolonged use, the 2900 range is made from NITRUM® high performance stainless steel. In addition to being treated with Bacteriaproof® silver to reduce presence of bacteria, the injection molded, ergonomically designed Polypropylene Copolymer (PP-C) handle is also non-slip and shock and temperature resistant. The 2900 series is available in a range of HACCP colours and is ideal for maintaining hygienic controls and ensuring compliance with food safety regulations.



Cooks Knives



8.2921

- Blade (L) : 200mm
- Full (L) : 332mm

- 8.292100 ● 8.292121 ● 8.292122
- 8.292123 ○ 8.292124 ● 8.292125



8.2922

- Blade (L) : 250mm
- Full (L) : 383mm

- 8.292200 ● 8.292221 ● 8.292222
- 8.292223 ○ 8.292124 ● 8.292225 ● 8.292228



8.2923

- Blade (L) : 300mm
- Full (L) : 432mm

- 8.292325

Chefs Knives

- Wide Blade



8.2907

- Blade (L) : 200mm
- Full (L) : 336mm

- 8.290700 ● 8.290721 ● 8.290722
- 8.290723 ○ 8.290724 ● 8.290725



8.2908

- Blade (L) : 250mm
- Full (L) : 387mm

- 8.290800 ● 8.290821 ● 8.290822
- 8.290823 ○ 8.290824 ● 8.290825 ● 8.290828



8.2909

- Blade (L) : 300mm
- Full (L) : 435mm

- 8.290925

Butcher Knives



8.2926

- Blade (L) : 200mm
- Full (L) : 345mm

- 8.292600 ● 8.292622
- 8.292623 ● 8.292625



8.2927

- Blade (L) : 250mm
- Full (L) : 395mm

- 8.292700 ● 8.292721 ● 8.292722
- 8.292723 ● 8.292725



8.2928

- Blade (L) : 300mm
- Full (L) : 445mm

- 8.292825

Boning Knives A thin Blade, with a characteristic curve and smooth edge. Perfect for slicing when separating the meat from the bones.

- Narrow Blade



8.2941

- Blade (L) : 160mm
- Full (L): 292mm

● 8.294125

- Broad Blade



8.2945

- Blade (L) : 160mm
- Full (L): 295mm

● 8.294500 ● 8.294521 ● 8.294522
● 8.294523 ○ 8.294524 ● 8.294525

- Color PROF Series



8.2422

- Blade (L) : 140mm
- Full (L): 281mm

- COLOR CLIP indicator for HACCP
- Polypropylene handle with an elastomer coating.
- Non-slip.
- Ergonomic design for easy handling.

Skinning Knives



8.2953

- Blade (L) : 160mm
- Full (L): 294mm

● 8.295300 ● 8.295322
● 8.295323 ● 8.295325



8.2954

- Blade (L) : 190mm
- Full (L): 322mm

● 8.295400 ● 8.295422
● 8.295423 ● 8.295425



Slicing Knives The 2900 series slicing knife features a long, thin blade that will help you cut and serve slices of meat.



- Plain Blade
- Blade (L) : 290mm
- Full (L): 445mm

● 8.293425



- Serrated Blade
- Blade (L) : 290mm
- Full (L): 445mm

● 8.293725



Pastry & Bread Knives

8.2932

- Blade (L) : 250mm
- Full (L): 385mm

● 8.293225



- Blade (L) : 200mm
- Full (L): 320mm

● 8.291425



- ARVI Range
- Blade (L) : 200mm
- Full (L): 320mm

● 8.7412



2900 Blister Pack : Paring , Vegetable , Sole & Santoku Knives



- Blade (L) : 80mm
- Full (L) : 190mm

● 8.290025



- Blade (L) : 100mm
- Full (L) : 210mm

● 8.290125



- Blade (L) : 170mm
- Full (L) : 298mm

● 8.293125



- Blade (L) : 180mm
- Full (L) : 312mm

● 8.290625



Carving / Fillet Knives , Forks



- Blade (L) : 200mm
- Full (L) : 336mm

● 8.294825



- Blade (L) : 250mm
- Full (L) : 392mm

● 8.295525



- Blade (L) : 180mm
- Full (L) : 314mm

● 8.290325

Cleavers

- Wide, sturdy blade with a rectangular shape. Suitable for cutting large pieces of meat and chopping through tendon.



8.2972

- Blade (L) : 220mm , .4mm thickness
- Full (L) : 338mm

● 8.297225



8.2975

- Blade (L) : 240mm , .4mm thickness
- Full (L) : 375mm

● 8.297500 ● 8.297525

Knife Sharpeners

Chromium plated Carbon Sharpening Steel



8.2792

- Blade (L) : 280mm / 17mm diameter ,
- Made of diamond-coated chrome-plated carbon steel for an expert results
- Black polypropylene handle, a material that helps to improve the grip.



Pull thru Sharpener



8.6106

- Full (L) : 230x60x50mm

Steel Sharpener



8.2784

- Blade (L) : 250mm/10mm diameter

Pro Chef Series : Scissors



8.784901

- Blade (L) : 80mm
- Full (L): 195mm



8.185601

- Blade (L) : 100mm
- Full (L): 215mm



8.185701

- Blade (L) : 110mm
- Full (L): 235mm

Poultry Sheers



8.5390

- DELUXE RANGE , S/S
- Blade (L) : 100mm
- Full (L): 336mm



8.5391

- Blade (L) : 100mm
- Full (L): 160mm



Fish Gadgets & Peelers



8.2772

Oyster Knife

- Blade (L) : 60mm
- Full (L): 170mm



8.4857

Pen Knife

- Blade (L) : 85mm
- Full (L): 198mm



8.6050

Fish Tweezer

- Blade (L) : 110mm
- Full (L): 130mm



8.7905

Fish Scaler

- Blade (L) : 100mm
- Full (L): 260mm

Peeler



8.6050

Potato Peeler

- Blade (L) : 50mm
- Full (L): 120mm

ARCOS® KNIFE ROLLS

The safest and most practical way for professionals when transporting all knives and kitchen gadgets.



- Material: 100% Polyester
- additional pockets available for small gadgets
- Knives not included



8.6902

- 4 pocket Knife bag
- Size : 460x275mm



8.6904

- 8 pocket Knife bag
- Size : 500x510mm



8.6905

- 12 pocket Knife bag
- Size : 730x510mm

Chain Mail Gloves



- 11.rtcmg - Small / White / Palm (L) 120mm
- 11.rtcmg - Medium / Red / Palm (L) 125mm
- 11.rtcmg - Large / Blue / Palm (L) 135mm

- Stainless steel chainmail glove , Ambi-dexterous ,
- Wrist length , 5 finger chainmail , Tapered fit design
- Washable, follow appropriate cleaning guides.
- Adjustable 20mm colour coded fastening wrist band.

Butcher Hook

1.BH

T BUTCHER HOOK

- High Quality Stainless steel 430
- Size : 109.2x60x200.6mm



ARCOS® NOVA SERIES

Highly resistant and durable NITRUM® stainless steel blade, specifically designed for peeling fruits and root vegetables. Its contemporary and ergonomic designed handle made from Polypropylene confers distinction and lightness, also available in HACCP Colors

Birds Beak / Shaping Knife

8.188300

- Black
- Used for Shaping & carving designs
- Inward curve conforms to round objects
- Sharp tip spear like to design
- Effortless peeling & pitting of fruit



Paring Knives

8.188600

- Black

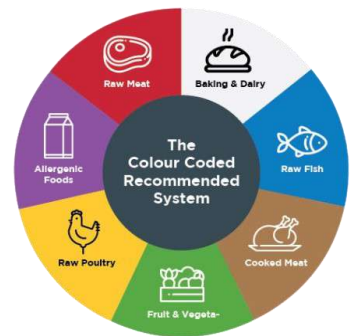

Choose a color ?

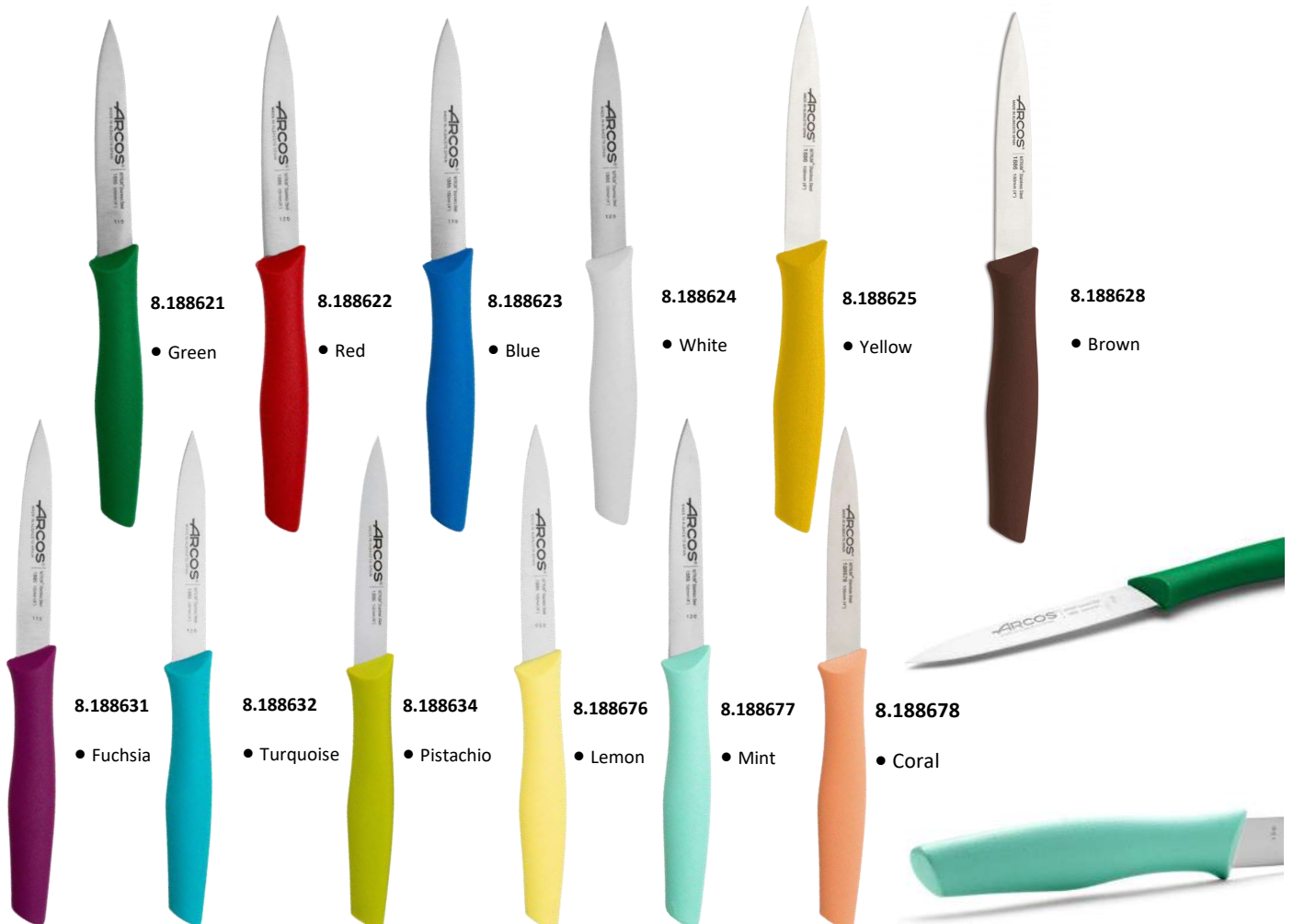

ARCOS[®] NOVA SERIES

Paring Knives - Serrated

The Nova Series 100mm paring knife is the ideal product for cutting and cleaning root vegetables and fruits.



8.188610

• Black

8.188611

• Green

8.188612

• Red

8.188613

• Blue

8.188614

• White

8.188615

• Yellow

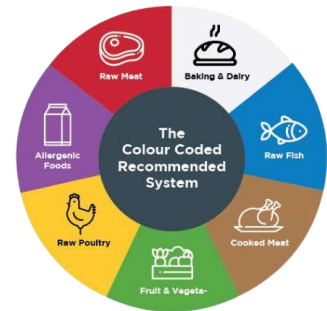

Table / Utility Knives - Serrated

The table knife is a tool for everyday use at the table and in the kitchen. It is intended for cutting soft foods or soft-textured steaks, but you can also use it to spread creams, sauces or butter. It has a 110 mm blade, rounded tip and pearly edge, which will guarantee a very efficient cutting process. It is also a light piece, weighing just 28 grams, which will be very comfortable when you use it.



8.188800

• Black

110 mm / 4"

200 mm / 8"

8.188821

• Green

8.188822

• Red

8.188823

• Blue

8.188824

• White

8.188825

• Yellow



ARCOS® NOVA SERIES

Cheese Knife - Serrated

The **Nova series cheese knife 105 mm** is the ideal tool for cutting semi-soft, semi-hard or hard cheeses without damaging it during cutting. It has a double tip that is really practical for cutting and pricking.

Features

- **Serrated tip:** It allows you to easily pick up the pieces of cheese, which are being chopped on a board.
- **Ergonomic handle:** It is made of injected propylene, so it provides a great grip and is resistant to high temperatures.
- **Stainless steel:** It has a type of steel exclusive to the Nova series, in Nitrum, which provides greater cutting hardness.
- **Dishwasher safe:** Although [it is recommended to clean it by hand](#) with a soft sponge.



8.188700

- Cheese Knife



B Line Series Utility Knives

The **B-Line knife** is a culinary piece inspired by pop art, a color range that inspires freshness and that will accompany your healthiest recipes. Will it win you over at the first cut? Of course it will. Because it has a resistant stainless steel blade, you can use it in your kitchen, on your trips to the countryside or the beach, in the office, for those moments when you need to take a break, let its extraordinary cutting power surprise you! Strong with a thin blade. Used to cut steak fillets, lightly grilled meat, fruit or vegetable.

Features

- Its **micro-perforated** edge allows you to cut all types of food with great ease.
- Double injection polypropylene handle, a corrosion resistant material.
- It has a cardboard sheath where you can store it.
- Dishwasher safe. It is recommended to dry by hand after each wash.
- Size: 215 mm (100 mm blade and 115 mm handle).



8.373624

- White Stripe



8.373631

- Fuchsia Stripe



8.373632

- Turquoise Stripe



8.373652

- Red



8.373656

- Yellow



8.373651

- Pistachio

CANTEEN SERVICE

Cafeteria Trays

- Heavy Duty 430 stainless steel
- .8mm gauge , durable & long lasting
- Mirror polishing

1.ct3 3 DIVISION CAFETERIA TRAY

- Size : 340x265x30mm

1.ct4 4 DIVISION CAFETERIA TRAY

- Size : 350x310x35mm



Pie Dishes



1.pd1 PIE DISH SMALL / Size 205x30mm

1.pd3 PIE DISH Large / Size : 240x40mm

Mine Feeding Dishes



1.mfd1 / Size : 265x45mm

1.mfd2 / Size : 290x60mm

Mugs, Bowls & Plates

- Stainless steel



4.m7 MUG / Size : 8cm/ 250 ml



4. Round Bowls , refer to page 22



11.pd2 PIE DISH MEDUIM / Size : 240x40mm (W: 240 GRAMS)



4.lpd3 FEEDING PLATE / Size : 240x40mm (W: 140 GRAMS)

Buckets & Lids

- Stainless steel
- Mirror polishing



4.buc12 APPROX 11.5LT BUCKET & LID

4.buc15 APPROX 13.5LT BUCKET & LID

4.buc20 APPROX 18LT BUCKET & LID

Prep Bowls / Sinks

- Heavy Duty
- 430 stainless steel
- .8mm gauge
- Durable & long lasting
- Waste outlet +/- 50mm



11.sink 450 mm PREP BOWL

11.sink3 340 mm PREP BOWL

CANTEEN SERVICE



Instant Boiling Water Solutions

- Available in Stainless Steel or White Epoxy Outer Casing
- Size : 2.5, 5, 7.5, 10 , 15 & 25 Liters , specs is listed below



Why Choose the Kwik Boil

- Wall mounted fully automatic , convenient
- On tap boiling water
- Advance Electronic controls
- Safe , Hygiene & Energy efficient , less prone to scale build up
- Steam free , No dangerous hot steam expelled from the unit.
- Diagnostic PC board for fault finding
- Additional safety sensor , prevents unit from overflowing , indicates when water probe needs a service.
- Efficient filling method : Saves Electricity & time by filling in stages, Improves productivity
- Boiling water within 15 minutes of initial start up thereafter boiling water will always be available at any given point. (Element activates once the temperature drops by 2 Degrees below boiling point.)
- NB : Operates at 230 Volts AC, 50 Hz, single phase electricity. Flexible 1.5m electrical cord with a 3 pin plug is fitted to all units.
- One year warranty from date of sale , Terms & conditions apply.

Product code - white epoxy	KB-2.5W	KB- 5W	KB 7.5W	KB- 10W	KB- 15W	KB-25W
Product code - stainless steel	KB-2.5 S/S	KB - 5 S/S	KB- 7.5 S/S	KB- 10 S/S	KB - 15 S/S	KB - 25 S/S
Nominal storage capacity (litres)	2,5	5	7,5	10	15	25
Initial draw-off (180ml cups)	15	30	45	60	100	150
Recovery per min (180ml cups)	2	2	2	2	2,5	3
First hour delivery (180ml cups)	120	135	150	175	200	270
Approx. time for 1st cup (mins)	6	7	7	10	11	11
Heating element input (k	1.8	2,0	2,0	2,0	2,4	3,0
Min. supply pressure (kPa)	20	20	20	20	20	20
Max. supply pressure (kPa)	1 000	1 000	1 000	1 000	1 000	1 000
Approx. weight empty (kg)	6,6	8,5	8,7	10	11,2	14,2
Approx weight full (kg)	10,7	16,3	18,3	25,5	30,4	47,2

Buyers Product Information Guide

Product Details : Dimensions , Volumes, Weights / Carrying Capacity

- All dimensions is listed in mm (millimeters)
- Please treat all measurements as approximate and subject to change.
- Volume capacities is listed in LT (liters) or ML (milliliters) , these are approximate & subject to change.
- All product weights is approximate and are subject to change.
- Please treat all carrying capacity listed as a guide and approximate, which is subject to change

Important Notes

- Where applicable, please request safety or care instructions regarding product use, storage & stock rotation.
- Products may differ slightly from the pictures listed in this catalogue
- Details provided is based on manufacturers information and may vary.
- In an effort to ensure the purchaser makes the right buying choice we have included as much information as possible, we have also aimed to present this information in a summary, easy to read & unambiguous format.
- Where applicable, Terms and Conditions apply to product warranty
- Please contact our offices should require any further information.

Key Symbols



GastroNorm sizes



Easy to take out



Transparent



BPA free products



Airtight



Color coding



Ergonomic



Permanent IML label



Optimum shape



Closing latch



Measuring scale



Granton Edge



Easy to clean



Ergonomic



Flexible Blade

Disclaimer

- Suppliers may change product specifications or discontinued lines without notice, therefore we reserve the right to discontinue any product without prior notice.
- Whilst we have made every effort to ensure all information provided is accurate, errors do occur , therefore all information provided in the catalogue is subject to E & OE.

Index

ITEM	PAGE	ITEM	PAGE	ITEM	PAGE
A-B		D		I & J	
AIRTIGHT GN LIDS - NEW	28	DOME/CLOCHE	14	ICE BUCKETS & STANDS	9
ASHTRAYS	10	DOUBLE ROASTERS	21	ICE CREAM CUPS	14
BAIN MARIE INSERTS	5,6,7	DREDGERS	37	ICE CREAM SCOOPS	35
BAR BLADES - NEW	10	DRAIN TRAYS - ARAVEN	31	ICE TONGS	9
BARBECUE SET - NEW	46			INDUCTION CHAFING DISH	2
BARWARE	9,10,11	E		INGREDIENT BINS	30
BASTING SPOONS	33	ECONO DISHES	22	INSERTS	5,6,7
BELLIED MILK JUGS	13	ECONO FEEDING PLATE	55	INSERTS PERFORATED	6
BEVERAGE DISPENSER	1	ECONO TRAY	11	INSTANT BOILING UNITS	56
BILL HOLDER	39	EGG CUPS	14	JUGS	36
BILL SPIKES	39	EGG RINGS	37	JUICE DISPENSER	1
BLACK FOOD PAN'S - ARAVEN	28	ELITE ROLL TOP CHAFER - NEW	3		
BLOCK SETS	45			K	
BOWLS & BASINS	22	F		KNIVES, COOKS, CHEFS	42, 44, 47
BREAD KNIVES	42,44,48	FAST FOOD TRAYS	11	KITCHEN SCISSORS	50
BUCKETS & LIDS	55	FINGER BOWLS	14, 22	KITCHEN TOOLS	33-54
BUTCHER HOOKS - NEW	51	FISH BONE TWEEZERS	34, 50	KNIFE ROLL BAGS	51
BUTTER DISHES	14	FISH SCALER	34, 50	KNIVES BONING & SKINNING	42, 44, 48
		FOOD DISPLAY COVERS	8	KNIVES BREAD	42, 44, 48
C		FOOD PAN - BLACK	28	KNIVES BUTCHER	48
CAFETERIA TRAYS	55	FOOD PAN - ROUND	7	KNIVES CARVING	42, 44,46, 49
CAKE COVERS	8	FOOD PAN KIT	7	KNIVES CHEESE	44, 54
CAKE STANDS	8	FORKS	33, 42, 46, 49	KNIVES CLEAVER	49
CAKE DISPLAY SETS	8	FRENCH WHISK	33	KNIVES OYSTER	50
CAKE SCRAPERS	36	FROTHING JUGS	13	KNIVES PARING	42, 44,49, 52-53
CASSEROLES	17,18,19	FRYING PANS - S/STEEL	19	KNIVES PASTRY	48
CEREAL DISPENSER	1	FRYING PANS NON STICK	20	KNIVES RIVERA RANGE (FORGED)	42
CHAFERS ROLL TOP	2,3	FUEL HOLDER	4	KNIVES SANTOKU/ JAPANESE	42, 44, 49
CHAFING DISH FUEL	4			KNIVES SETS - NEW	45, 46
CHAFING DISHES	2,3	G		KNIVES SLICING	48
CHAIN MAIL GLOVE	51	GASTRONORM INSERTS	5, 6, 7	KNIVES STEAK - NEW	46
CHAMPAGNE BUCKET	9	GLOVE CHAINMAIL	51	KNIVES TABLE / DESSERT	15
CHEESE KNIVES	44, 54	GN DRAIN TRAYS/ GRILLS	31	KNIVES UNIVERSAL RANGE	44
CHOPPING BOARD RACK	38	GN STORAGE CONTAINERS	26, 27, 28	KNIVES UTILITY	49, 53-54
CHOPPING BOARDS	38	GRAVY BOATS	14	KWIKBOILS	56
CLEAVERS	49	GRILL RACK - NEW	21		
COFFEE PERCOLATOR	12	GRILL PAN	20	L, M, N, O	
COLANDERS	22			LADLES ONE PIECE	33
CONVECTION OVEN RACK - NEW	5			MAGNETIC KNIFE RACKS	39
COOLING DISPLAY SETS	8	H		MEASURING CUPS SET	36
CRUET SETS	14	HAMBURGER TURNERS	34	MEASURING JUGS - S/S	36
CURRY AND RICE SPOONS	33	HEAVY DUTY INSERTS & LIDS	5	MEASURING JUGS -PP	36
CUTLERY - E LOFF	15	HORECA MARKER	27	MEASURING SPOONS SET	36
CUTLERY BOX	39	HOTEL POTS	17, 18, 19	MEDICAL BOWL (TAPERED)	22
CUTLERY SETS - NEW	15				

Index

ITEM	PAGE	ITEM	PAGE	ITEM	PAGE
L, M, N ,O - Continued		S		W	
MILK JUGS	13	SALAD SERVERS	33	WAITER'S FRIEND WINE OPENER	10
MINE FEEDING DISHES	55	SALT & PEPPERS SETS	14	WHISKS	33
MINI DOUBLE ROASTER	21	SAUCE CUPS	14	WINE BUCKETS	9
MINI MIXERS	22	SAUCE DISPENSERS	31	WINE STANDS	9
MIXING BOWLS	22	SAUCE PANS	18, 19		
MIXING PADDLE	37	SCISSORS	50		
MUGS	55	SCOOPS	35		
NON SLIP TRAY	11	SERVING SPOONS	33		
NON STICK FRYING PANS	20	SHARPENING STEELS	49		
OYSTER KNIVES	50	SINK BOWLS	55		
		SK/ SINGLE ROASTERS	21		
		SLOTTED TURNERS	33		
P		SPATULA'S	36, 44		
PALLET KNIVES	36	SPOUTED TEAPOTS	12		
PEELER	50	STAND FOR WINE BUCKET	9		
PEN KNIVES	50	STEAK KNIVES	46		
PIE DISHES	55	STOCK POTS	17		
PIZZA CUTTER / LUNAR BLADE	37	STORAGE CONTAINERS	26-27		
PIZZA SHOVEL/TURNER	37	SUGAR BASINS	13		
PLASTIC TRAYS	11	SUNDAE CUPS	14		
PLASTIC/POLY CARB COVERS	8				
PLATE COVERS	14	T			
POLY RATTAN BASKET	8	TAPERED BOWLS	22		
POLYCARB SCOOPS	35	TEA POTS	12		
PORTION SCOOPS / SERVERS - NEW	35	TEA POTS SPOUTED	12		
POTS & PANS	16-20	TOAST RACKS	14		
POULTRY SHEARS	50	TONGS	34		
PREMIUM CHAFERS	2	TOT DRAINERS	9		
PREP BOWLS	55	TOTE BOX	39		
PUNCH BOWLS	9	TRAYS RECTANGULAR S/S	11		
POT FORKS	33	TRAYS ROUND	11		
PERORATED TURNERS	34	TROLLEYS	12		
PARING KNIVES	52-53	TURNERS	33, 34		
		TWO HANDLE CHOPPING KNIFE	37		
R					
RACK FOR CHOPPING BOARDS	38	U & V			
RICE SPOON	33	UTILITY TONGS	34		
ROASTING PANS	21, 22	UTILITY TRAYS	11		
ROLL TOP CHAFERS	3	VEGETABLE DISHES	14		
ROUND BOWLS	22	VINYL TONGS	34		
ROUND FOOD PAN	7				
ROUND TRAYS	11				



Let's Get In Touch

Contact Us

Info@Absolutecateringequipment.co.za
011 334 8025

Visit Us

11 Mooi Street
Wemmer
Johannesburg
2001

Visit Our Website

www.Absolutecateringequipment.co.za

OR

Scan Here to Visit Our Website

